

Oct. 24, 1961

G. K. CHRISTIANSEN

3,005,282

TOY BUILDING BRICK

Filed July 28, 1958

2 Sheets-Sheet 1

FIG. 1.

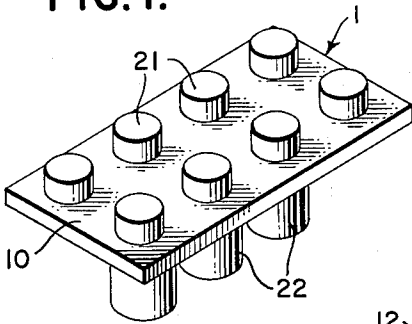

FIG. 2.

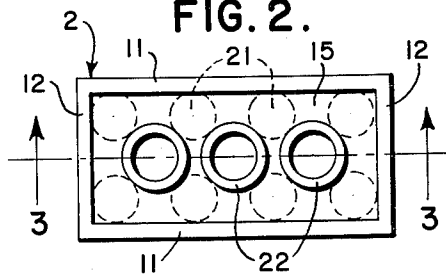

FIG. 3.

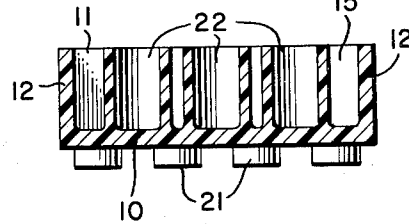

FIG. 4.

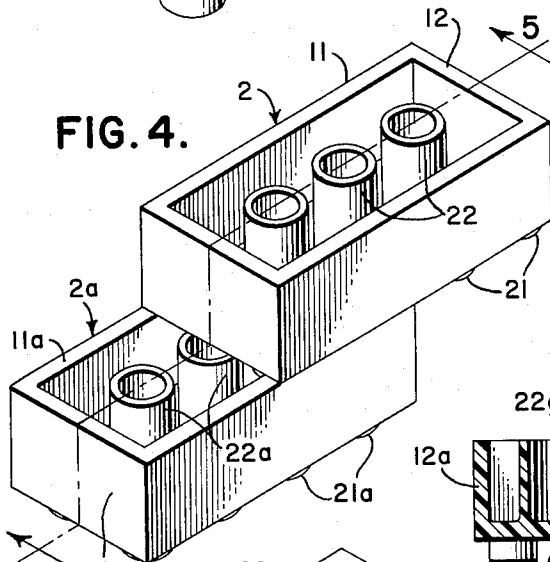

FIG. 5.

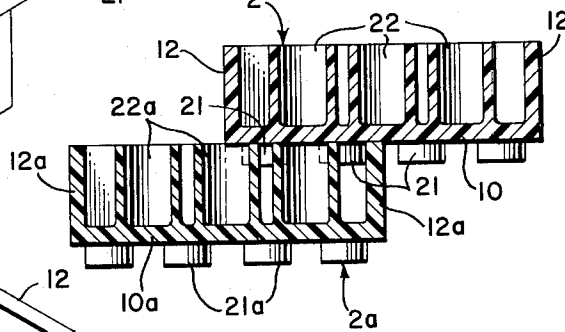
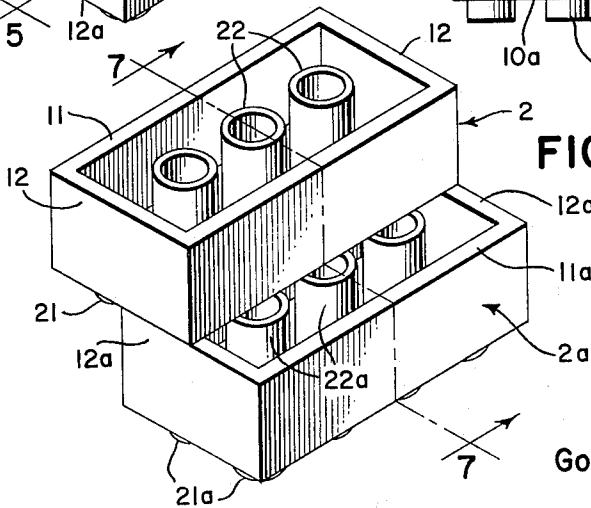

FIG. 6.



INVENTOR

Godtfred Kirk Christiansen

BY
Stevens, David, Muller, & Mosher
ATTORNEYS

Oct. 24, 1961

G. K. CHRISTIANSEN

3,005,282

TOY BUILDING BRICK

Filed July 28, 1958

2 Sheets-Sheet 2

FIG. 7.

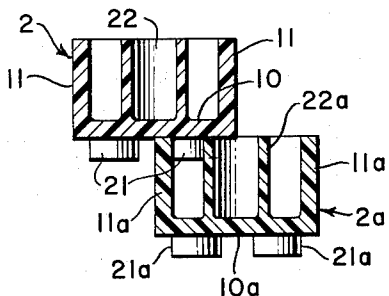

FIG. 8.

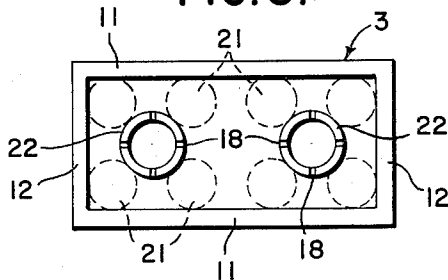

FIG. 9.

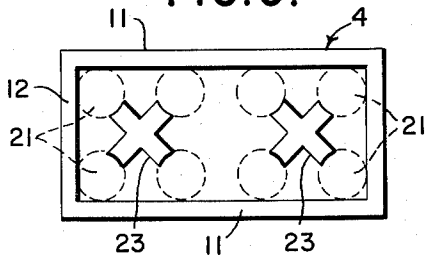

FIG. 10.

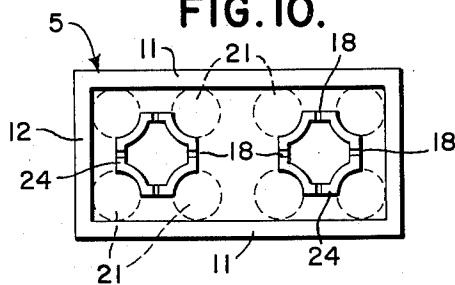

FIG. 11.

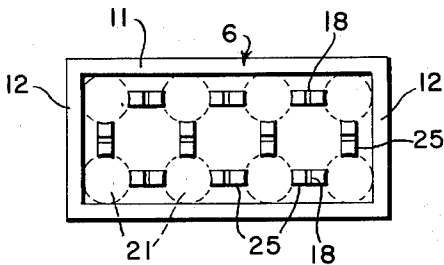
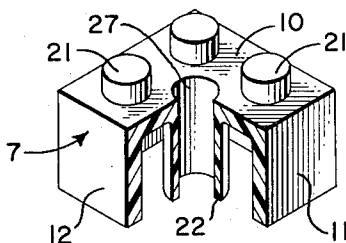

FIG. 12.



INVENTOR

Godtfred Kirk Christiansen

BY
Stevens, Davis, Miller & Mosher
ATTORNEYS

1

3,005,282

TOY BUILDING BRICK

Godtfred Kirk Christiansen, Billund, Denmark, assignor to Interlego A.G., Zug, Switzerland, a corporation of Switzerland

Filed July 28, 1958, Ser. No. 751,387

Claims priority, application Denmark Jan. 28, 1958

7 Claims. (Cl. 46—25)

This invention relates to toy building elements and more particularly to toy building bricks or blocks adapted to be connected together by means of projections extending from the faces of the elements and arranged so as to engage protruding portions of an adjacent element when two such elements are assembled.

Toy elements of this kind will be referred to generally as building bricks, and the principal object of the invention is to provide improved coupling means for clamping such building bricks together in any desired relative position thus providing for a vast variety of combinations of the bricks for making toy structures of many different kinds and shapes.

Fundamentally, a toy building element according to the invention comprises a base plate provided with projections at either face thereof, the projections at one face being arranged in such a manner relatively to the projections at the other face that the distance between a pair of projections at one face of the base plate is equal to the maximum of the projections at the other face of the base plate.

Other embodiments of the invention, including building blocks in the shape of a rectangular parallelepiped of a hollow construction having one open face, will be described with reference to the accompanying drawings, in which:

FIG. 1 is a view of a toy brick of the basic type comprising a base plate provided with projections at both faces.

FIGURE 2 is a plan view in the direction of the open face of a preferred embodiment of the invention in the form of a building block in the shape of a rectangular parallelepiped of hollow construction with one open face and four side walls;

FIGURE 3 shows a section of the block shown in FIGURE 2, along the line 3—3 in the direction of the arrows;

FIGURE 4 illustrates the assembly of two blocks displaced relative to one another in the lengthwise direction thereof;

FIGURE 5 shows a section of the coupled blocks 2, 2a taken on the line 5—5 of FIGURE 4 looking in the direction of the arrows;

FIGURE 6 is a view wherein the two blocks are laterally displaced relative to one another;

FIGURE 7 shows a section of the coupled blocks 2, 2a along the line 7—7 of FIGURE 6 looking in the direction of the arrows;

FIGURE 8 is a plan view showing a block similar to those illustrated in FIGURES 2-7, but having only two internal projections;

FIGURE 9 is a modification of the block shown in FIGURE 8;

FIGURES 10 and 11 show further modifications of the block shown in FIGURE 8;

FIGURE 12 is a view of a block comprising a square base plate with four projections at the external face, one corner being cut away to show the internal projection.

The base plate, constituting the fundamental element of the brick, is generally designated by 1, the projections extending from one face of the base plate are hereinafter referred to as the primary projections 21, and the projections at the other face are referred to as the sec-

2

ondary projections 22. In the embodiments of FIGS. 2-12, where in the base plate 10 is provided with side walls 11 and end walls 12, so as to constitute a hollow block open at one face, the primary projections are located at the external face of the bottom formed by the base plate 10, and the secondary projections 22 are located in the cavity of the hollow block.

In the plan views, FIGURES 2, 8, 9, 10 and 11, the primary projections 21 on the outer face of the base are indicated by the smaller circles in broken lines. Each of the secondary projections touches the geometrically projected cross sections of four primary projections. Likewise the geometrically projected cross-section of each primary projection is tangent to at least one secondary projection and the inner face of at least one of the side or end walls.

The primary projections 21 are arranged in two rows parallel to the long edges of the rectangular base 10, and a standard set of bricks generally comprises units having four, six, and eight primary projections, although the invention is naturally not limited to the use of such standard units, but also comprises base plates having a large number of primary projections 21. Bricks provided with primary projections arranged in this manner are well-known per se.

It is also well-known to provide hollow building blocks with internal projections located in the cavity, but in the previously known blocks of this type the internal projections are arranged co-axially with the primary projections.

In contradistinction to prior art, however, the secondary projections 22 according to this invention are arranged co-axially with the centre of a square defined by four primary projections 21, the cross section of the secondary projections 22 being defined in such a manner that it touches the cross sections of the four primary projections defining said square when said cross-sections are geometrically projected normal to the bottom wall.

Preferably, both the primary and the secondary projections are of cylindrical shape, and the circular cross section of the secondary projections *s* will thus touch the four circular cross sections of the primary projections 21.

In the embodiments shown in FIGS. 1, 2, 3, 4, 5, 6, 7, 8 and 12 the secondary projections 22 are of tubular shape, having a cylindrical cavity therein as shown more clearly in the sectional views, FIGURES 3, 5, 7 and 12. Other cross sections may, however, be used as shown in FIGS. 9 and 10, where the secondary projections are cross-shaped, or they may have any other symmetrical cross section provided that the contour of the cross section is shaped so as to contact the circular cross sections of four primary projections as shown by way of example in FIGURE 11. The secondary projections may be provided with longitudinal slits 18, as shown in FIGS. 8, 10 and 11, to increase the clamping effect of said projections, when interlocked with four primary projections of an adjacent brick.

This particular disposition of the secondary projections relative to the primary projections which is the essential feature of the invention provides for a vast number of possible combinations of adjacent bricks.

Although the clamping effect used for assembling a pair of adjacent bricks by engaging the secondary projections of one brick with four primary projections of the other brick is, fundamentally, independent of the presence of the side and end walls 11 and 12, the bricks according to the invention will preferably be provided with said walls so as to constitute hollow blocks of brick-like appearance, and the figures illustrating the assembly of two elements therefore show such blocks.

In the preferred embodiments the height of the sec-

3

ondary projections is equal to the depth of the cavity 15, and these projections will then co-operate both with the primary projections 21 of the adjacent block and with the inner faces of the side or end walls thereof as shown in FIGS. 4 and 6.

The blocks shown in FIGS. 8, 9 and 10 are provided with only two internal projections, but otherwise their construction and function are the same as in the case of FIGS. 2-7.

In FIG. 9 the cross-shaped secondary projections are designated by 23, and in FIG. 10 the corresponding secondary projections which are also substantially cross-shaped are designated by 24. These secondary projections are those of FIG. 11, which are designated by 25, co-operate with the primary projections 21 of an adjacent element in substantially the same manner as described with reference to the tubular projections of FIGS. 1-7.

Thus, any of the elements illustrated in FIGS. 2-11 may be combined with any other element in any desired relative position either by clamping one or more secondary projections of one element between four primary projections of the adjacent element or by clamping a pair of primary projections of one element between one secondary projection and the inner face of an end or side wall of the other element.

In the building block shown in FIG. 12 having a square bottom provided with four external primary projections 21, an opening 27 in the base 10 is aligned with the cavity of the tubular secondary projection, thereby providing for the insertion of a cylindrical connecting member, not shown, extending through the block co-axially with the centrally positioned secondary projection.

I claim:

1. In a toy building set, a hollow building block of rectangular parallelepiped shape comprising a bottom and four side walls, at least four cylindrical projections extending normally outwardly from said bottom and arranged in two rows of opposed projections to define a square, a tubular projection extending normally from the inner face of said bottom, and parallel to said side walls, the longitudinal axis of said tubular projection passing through the center of said square, and the peripheries of said cylindrical projections contacting said tubular projection and at least one side wall when said peripheries are geometrically projected normally to said bottom, whereby the cylindrical projections on one of said blocks may be inserted into clamping engagement with a tubular projection and a wall of another of said blocks.

2. A building block as set forth in claim 1, wherein the inside diameter of said tubular projection is equal to the diameter of said cylindrical projections,

4

3. In a toy building set, a pair of identical building blocks each comprising a hollow parallelepiped body open at one face and having a bottom and four side walls, primary projections extending normally outwardly from said bottom and arranged in two rows of opposed projections so that two adjacent pairs of said primary projections in each of said rows define a square, and at least one secondary projection on said bottom within the cavity coaxial with the center of one of said squares, the position of said primary projections relative to the walls and the secondary projection being such that a pair of primary projections of one block are clamped between at least one side wall and at least one secondary projection of the other block when said pair of identical blocks are assembled by inserting at least two primary projections of one block into the cavity of the other block.

4. A toy building block having a bottom wall, straight side walls each having an inner surface, said walls encompassing the inner face of said bottom wall, at least two identical primary protuberances extending from the outer face of said bottom wall, at least one secondary protuberance extending from said inner face of said bottom wall and presenting a surface within the region encompassed by the inner surfaces of said side walls, a geometric projection of the peripheries of said primary protuberances normal to the inner face of said bottom wall each being in tangential contact with said surfaces at three points, at least one of said points of contact being with the surface of said secondary protuberance, said tangential contact producing a clamping effect when a primary protuberance of another such block engages the said surfaces.

5. A toy building block according to claim 4 in which the block has eight primary protuberances and three secondary protuberances.

6. A toy building block according to claim 4 in which the secondary protuberances are cross-shaped.

7. A toy building block according to claim 5 in which the protuberances are circular in cross-section.

References Cited in the file of this patent

UNITED STATES PATENTS

556,271	Kleinberger	Mar. 10, 1896
879,455	Frost	Feb. 18, 1908
1,191,884	Finch	July 18, 1916
2,703,487	Ossoinack	Mar. 8, 1955

FOREIGN PATENTS

6,610	Great Britain	May 3, 1915
128,398	Australia	Sept. 15, 1945
940,270	France	of 1948
504,134	Belguim	of 1951
676,469	Great Britain	July 30, 1952

Disclaimer

3,005,282.—*Godtfred Kirk Christiansen*, Billund, Denmark. TOY BUILDING BRICK. Patent dated Oct. 24, 1961. Disclaimer filed Mar. 31, 1978, by the assignee, *Interlego A.G.*

Hereby enters this disclaimer to claims 1, 2 and 3 of said patent.

[*Official Gazette May 23, 1978.*]